

Description

GE ENERGY 3 is a ventilation appliance, equipped with a counter-flow heat exchanger with a recovery rate of up to 95%. This appliance has supply air and extract air fans with energy saving EC motors and backward curved fan blades. GE ENERGY 3 is equipped with a 100% modulating summer bypass.

As standard, the fresh air source has been filtered through an F8* (pollen filter) and the exhaust air has a G4 plain filter. GE ENERGY 3 is delivered with an Optima 250 Design controller.

GE ENERGY 3 can be fitted with the following options:

- Bag filter F5, F7 or a plain G4 filter
- Water or electrical heating element for mounting on the duct
- Water frost sensor
- Motor valve for heating element
- Fan guard and filter guard
- Fresh air valve, motor driven with spring return
- Hydrostat for moisture reduction ventilation

Suitability

GE ENERGY 3 is suitable for ventilating domestic properties where there is a demand for temperature efficiency and low energy consumption. This means that the new regulations for low energy consumption should be met.

GE ENERGY 3 can be used in living areas of up to 545m² at a ceiling height of 2.4m and that need an airflow of up to 655m³/h at 150 pa.

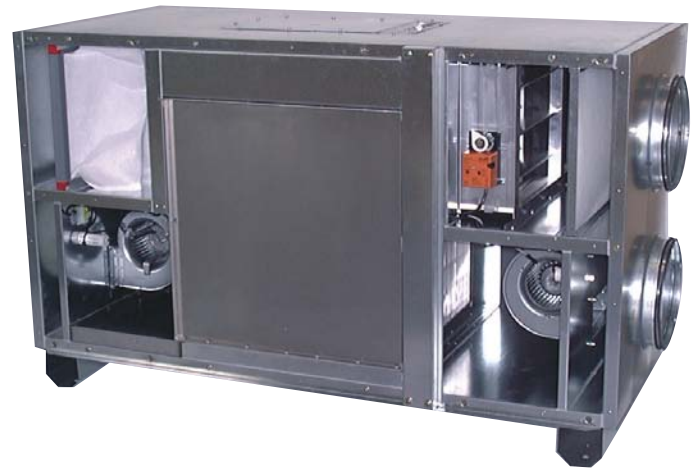
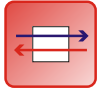

Types

GE ENERGY 3 can be fitted in either a left or a right hand version.

Dimensions

GE ENERGY 3 (right handed)

Dimensions in mm

Bypass:

GE ENERGY 3 is fitted with a 100% modulating summer bypass as standard.

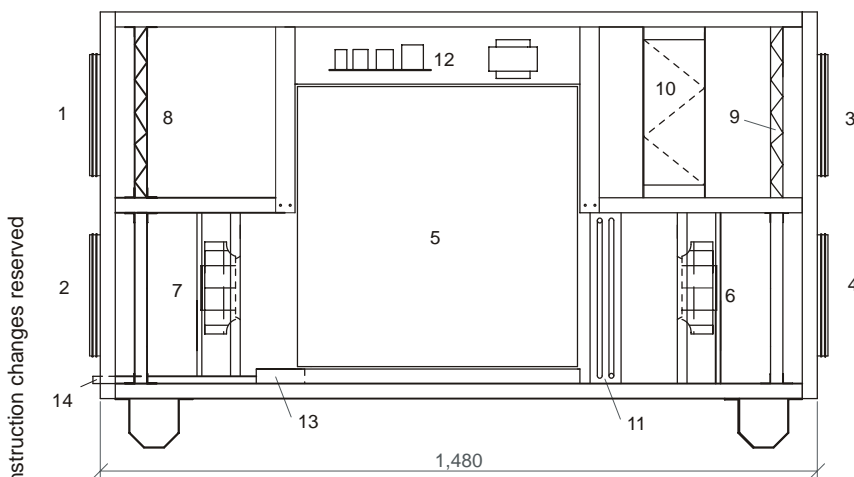

Construction changes reserved

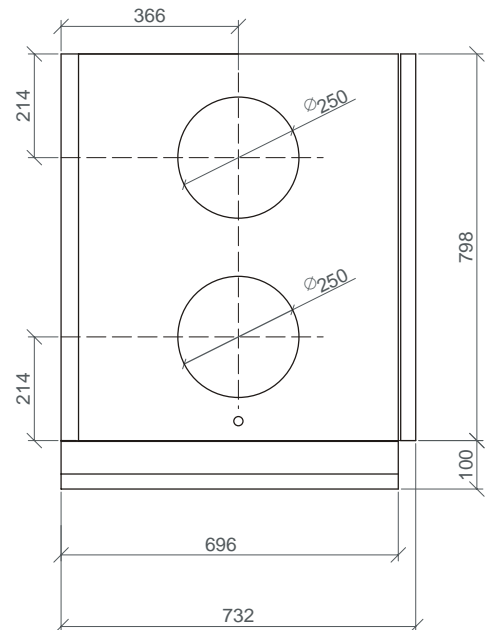

Minimum distance above unit for electrical connection 300mm

- | | |
|--------------------------------|------------------------------------|
| 1: Fresh air | 8: Fresh air filter |
| 2: Exhaust air | 9: Extract air filter |
| 3: Extract air | 10: Bypass valve |
| 4: Supply air | 11: Water heating element |
| 5: Counter flow heat exchanger | 12: Electric box |
| 6: Supply air fan | 13: Condensation tub |
| 7: Extract air fan | 14: Condensation connection Ø15 mm |

*F8 pollen filter fitted as standard in Great Britain only, otherwise G4 plain filters fitted



Technical data

Electrical connection

1 x 230 V + N, 10 A, 50 Hz

Fans

R3G 220 AE 50

Motor

EC-motor with integrated electronics

Isolation class

B

Class

IP 44

Motor Data:

3,510 Rpm

157W (max/motor)

1,10A (max/motor)

Construction

Size:

(l x d x h) excl. connections

1,480 x 732 x 898mm

Cabinet:

Double plated galvanized steel plate with 30mm insulation

Duct connection:

∅250mm with double rubber lip

Front:

Two parts, one folds down with quick locks for filter service

Back plate:

Mounted with 6mm bolts

Heat exchanger:

Sea-water resistant aluminium

Condensate pipe:

∅15 mm rust-proof steel

Filters:

G4 plain filters on extract air

F8 pollen filters on fresh air*

Weight:

200 kg

Automatic Settings

GE ENERGY 3 is delivered with a complete Optima 250 Design controller.

The Optima 250 is delivered with default factory settings, so that the appliance can be started, without first setting-up the menu. The factory settings are standard and can be changed to your requirements, thereby getting the most out of the appliance.

Control panel



Speed (1)

This sets the fan speed to levels 0-1-2-3-4.



Extended operation (2)

This sets the timer to forced operation from 0 to 9 hours.



After-heat (3)

This turns the supplementary after-heat on or off.



Temperature (7)

This sets the room temperature.



Information (6)

This gives a good overview of the appliance's current operating condition.



Filter (5)

Use this function to reset the filter alarm.

*F8 pollen filter fitted as standard in Great Britain only, otherwise G4 plain filters fitted

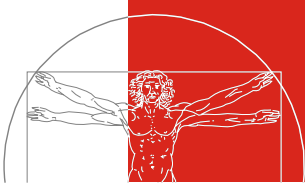

Capacity curves

Air volume and SFP 1,200 j/m³ line:

The capacity lines are based on average supply and extract air, in an appliance with plain filters.

- 1 = 100%
- 2 = 80%
- 3 = 60%
- 4 = 40%
- 5 = 25%
- 6 = SFP 2,100
- 7 = SFP 1,200

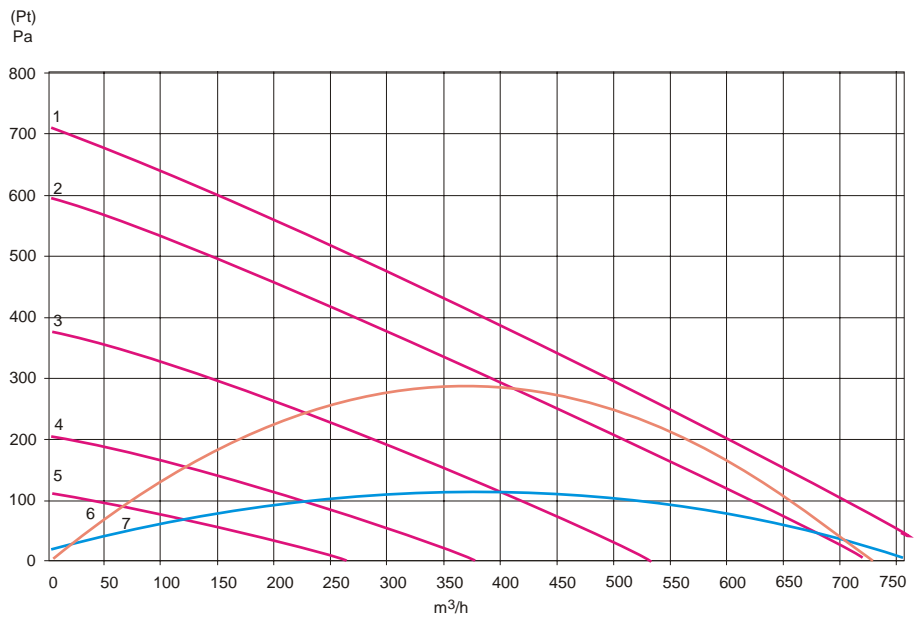

Total energy consumption:

For both fans and controller.

- 1 = 100%
- 2 = 80%
- 3 = 60%
- 4 = 40%
- 5 = 25%

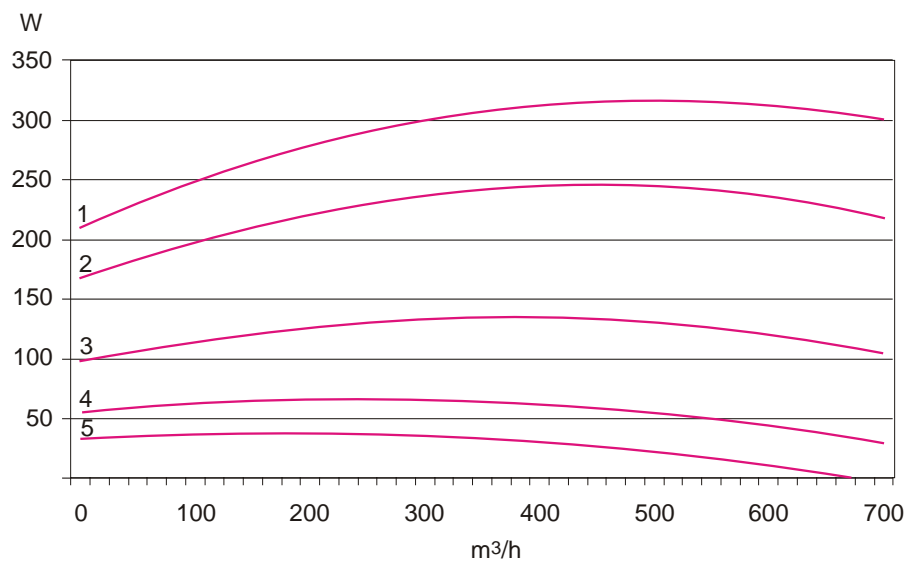

Heat recovery rate

Heat recovery rate, Volume flow $m_{ind} = m_{ud}$							
		A	B	C	D	E	F
Extract	°C	20	20	20	20	20	20
Relative humidity	%	30	50	70	30	50	70
Fresh air	°C	4	4	4	-12	-12	-12

NB: There has been no consideration taken for freezing of the heat exchanger at low external temperatures.

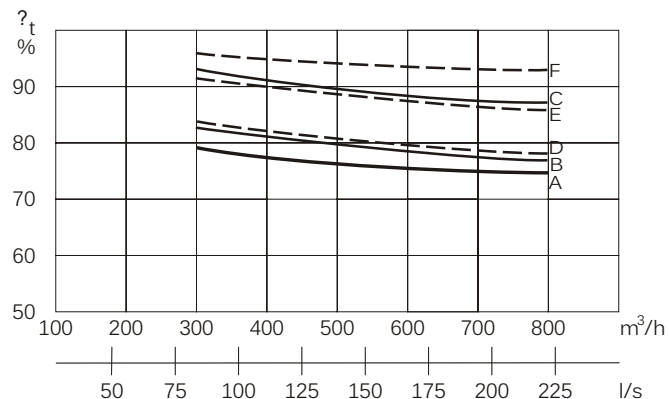



Sound data

Sound curves are made by interpolation of the sound data measured by The Danish Technologic Institute.

LWA Energy 3 Supply air duct

- 1 = 70dB
- 2 = 65dB
- 3 = 60dB
- 4 = 55dB
- 5 = 50dB
- 6 = 45dB
- 7 = 40dB
- 8 = 35dB

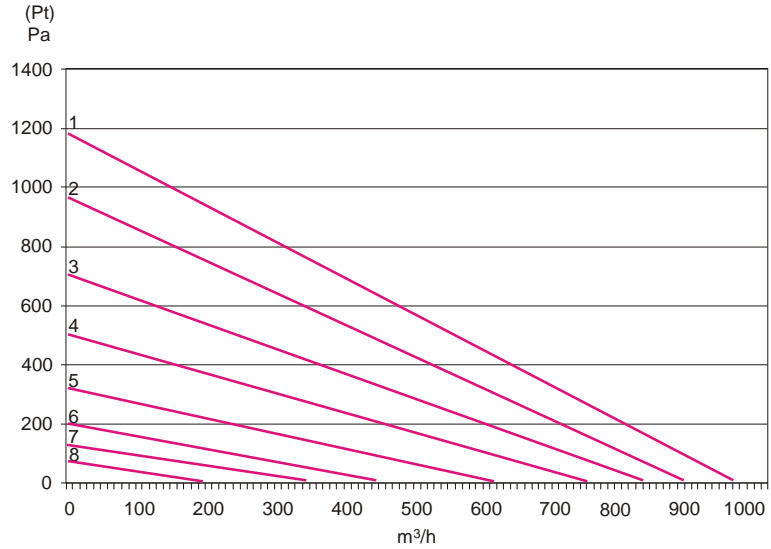

LWA Energy 3 Extract air duct

- 1 = 70dB
- 2 = 65dB
- 3 = 60dB
- 4 = 55dB
- 5 = 50dB
- 6 = 45dB
- 7 = 40dB
- 8 = 35dB

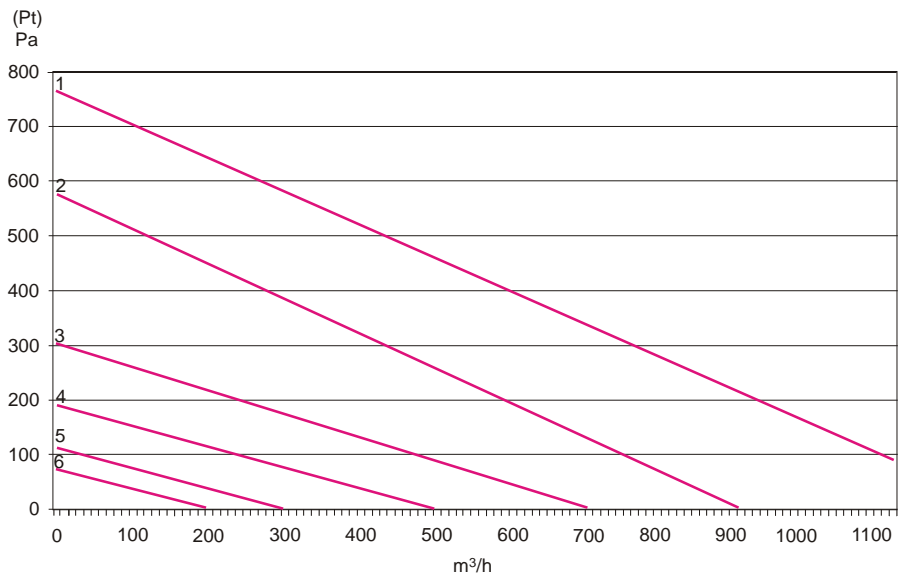

Correction tables:

Supply air duct:

		Correction figures							
	LwA	63	125	250	500	1k	2k	4k	8k
GE 3 Su	60-100	7	3	9	3	6	7	15	21
GE 3 Su	20-59	11	5	14	4	4	6	13	17

Extract air duct:

		Correction figures							
	LwA	63	125	250	500	1k	2k	4k	8k
GE 3 Ex	60-100	-1	-8	-2	4	7	10	24	28
GE 3 Ex	20-59	0	-9	0	0	-1	-5	24	28